



**PROVA DI AMMISSIONE AI CORSI DI LAUREA E DI LAUREA MAGISTRALE A CICLO UNICO
DIRETTAMENTE FINALIZZATI ALLA FORMAZIONE DI ARCHITETTO (IN LINGUA INGLESE)**

Anno Accademico 2018/2019

Logical Reasoning Test

1. **"All Italians love art. No lover of art is a coward"**
Therefore which one of the following is correct:
 - A) No coward is Italian
 - B) All art lovers are Italian
 - C) Some Italians are cowards
 - D) Every coward is Italian
 - E) Art lovers are not Italian

2. **Choose from amongst the following terms the one which is a synonym with "observation" and "height"**
 - A) survey
 - B) revelation
 - C) elevation
 - D) compilation
 - E) highlight

3. **alpha : X as Y : end**
 - A) X=beginning; Y=omega
 - B) X=beta; Y=middle
 - C) X=number; Y=figure
 - D) X=first; Y=beta
 - E) X=code; Y=first

4. **To be able to use the facilities of a tennis club, players pay a monthly fee plus a fee for every hour they use the courts. If players divide the hourly fee equally between themselves, and last month**
Michele, played 6 hours singles and 4 hours doubles and paid 120?
Giorgio, played 5 hours singles and 7 hours doubles and paid 125?
How much did Nicolò pay in euros when last month he played 3 hours singles and 8 hours doubles?
 - A) 110
 - B) 115
 - C) 95
 - D) 130
 - E) 100

5. Rectangle OCDE is inscribed in a circular sector AOB that has a 10 cm radius and a width of 90° . The OC side of the OCDE rectangle lies on radius OA, the OE side on side OB, and vertex D on the circumference arc. If side OC measures 5 cm, how long is the diagonal CE?
- A) 10 cm
 - B) 7,5 cm
 - C) 5 cm
 - D) 11 cm
 - E) 8 cm

6. Truth tables are tables used in logic to determine if, having assigned truth values to the propositions, a certain proposition is true or false. Truth tables of conjunction "e" (\wedge), disjunction "o" (\vee) and negation "not" (\neg) are respectively:

A	B	$A \wedge B$
V	V	V
V	F	F
F	V	F
F	F	F

A	B	$A \vee B$
V	V	V
V	F	V
F	V	V
F	F	F

A	$\neg A$
V	F
F	V

Knowing that the logical implication $A \Rightarrow B$ is equivalent (i.e., it has the same truth table) as the proposition $\neg A \vee B$, which is the truth table of the implication?

A)

A	B	$A \Rightarrow B$
V	V	V
V	F	F
F	V	V
F	F	V

B)

A	B	$A \Rightarrow B$
V	V	V
V	F	F
F	V	F
F	F	V

C)

A	B	$A \Rightarrow B$
V	V	V
V	F	V
F	V	F
F	F	V

D)

A	B	$A \Rightarrow B$
V	V	V
V	F	V
F	V	F
F	F	F

E)

A	B	$A \Rightarrow B$
V	V	F
V	F	V
F	V	V
F	F	F



7. Which one/ones of the following rules of substitution is/are correct?

- 1 all X are Y \Rightarrow all not Y are not X
 - 2 all X are Y \Rightarrow all not X are not Y
 - 3 some X are not Y \Rightarrow some Y are not X
- A) only the first
 - B) the first and the third
 - C) all three
 - D) none of the other
 - E) the first and second

8. Alice has to insert the missing number in the last table so that all the tables respect the same criteria. What number does Alice have to insert?

2	5
3	7

4	9
6	13

5	11
8	?

- A) 17
 - B) 18
 - C) 21
 - D) 19
 - E) 15
9. A box is divided into five equal rectangular compartments arranged in such a way that a longer side of a single compartment is in contact with the shorter side of the other four. The perimeter of the box measures 144 cm. What are the measurements of a compartment, in centimeters?
- A) 8 x 32
 - B) 10 x 50
 - C) 7 x 28
 - D) 6 x 24
 - E) 9 x 45
10. When the area of a circle increases by 44%, what is the percentage increase in the length of its circumference?
- A) 20%
 - B) 88%
 - C) 66%
 - D) 44%
 - E) 22%
11. Which one/ones of the following syllogisms is/are true?
- S1 some X are Y, every Z is X, so every Z is Y;
 - S2 every X is Y, some Z are not Y, so every Z is not X;
 - S3 no X is Y, some X are Z, so every Z is not Y.
- A) None
 - B) Only S1
 - C) All
 - D) S2 and S3
 - E) S1 and S3

12. If: $a \diamond b = ab$ and $a \square b = a/b$,
Which of the following operations has the same result as $(a \diamond b) \square (a \diamond a)$?
- A) $b \square a$
 - B) $a \square b$
 - C) $b \diamond a$
 - D) $a \square a$
 - E) $b \diamond b$
13. "If Nicolò enrolled in the downhill bike course in Bormio during Carnival Week, Alice could spend the afternoons of that week at the Spa".
If this statement is true, which statement/statements is/are logically correct:
- A During Carnival week Alice spends her afternoons at the Spa, therefore Nicolò has enrolled in the downhill bike course.
 - B Nicolò enrolled in the downhill bike course so during Carnival week Alice spends her afternoons at the Spa.
 - C During Carnival week Alice does not spend her afternoons at the Spa, therefore Nicolò has not enrolled in the downhill bike course.
 - D Nicolò has not enrolled in the downhill bike course, therefore Alice does not spend her afternoons at the Spa during Carnival week.
- A) B and C
 - B) A and D
 - C) A and C
 - D) B and D
 - E) All the above
14. In square Q with a side measuring 7 cm consider the two squares each with a side measuring 3 cm and sides parallel to the sides of Q, and:
the first has the same center as Q
the second with pairs of parallel sides respectively distant 1 cm, 3 cm and 1,5 cm, 2,5 cm from the sides of Q
What is the square centimeter measurement of the area shared by the two squares with 3 cm sides?
- A) 5
 - B) 4,5
 - C) 5,5
 - D) 4
 - E) 6
15. Having randomly chosen a natural number n, what are the probabilities that number n² ends in the figure 4?
- A) 20%
 - B) 0%
 - C) 10%
 - D) 40%
 - E) 25%



16. Giorgio is asked to continue the sequence:

2- 3 - 5 - 9 - 17 - 33 - ...

What is the next number Giorgio has to insert?

- A) 65
- B) 67
- C) 56
- D) 76
- E) 99

Excerpt 1

Read this excerpt and answer every question based only on the information provided (either explicitly or implicitly) in the excerpt and not on the knowledge that the candidate may have on this issue:

The use of gold is one of the clearest indicators of the decline in the medieval role of pigments as a display of conspicuous consumption. Gilding is clearly nonnaturalistic: gold leaf laid on a flat surface does not look like a three-dimensional golden object. Alberti warns that its appearance changes depending on how light is reflected: "When done in gold on a flat panel, many surfaces that should have been presented as light and gleaming, appear dark to the viewer, while others that should have been darker, probably look brighter".

He therefore exhorts the painter to render golden surfaces, such as brocade, using pigments and skill, not the metal itself – for "there is more admiration and praise for the painter who imitates the rays of gold with colours".

It is fascinating to follow the demise of gilding throughout the fifteenth century. A curious transitional piece between the medieval gold grounds and the later more naturalistic use of gold is *The Conversion of St. Hubertus* (second half of the fifteenth century) painted by the Workshop of the Master of the Life of the Virgin of Cologne. Here we find a gold "sky" juxtaposed with an attempt at a naturalistic landscape (although the painter shares none of Leonardo's attentiveness to nature and seems to have learned aerial perspective – the blueing of distant hills – from a book). In *Madonna with four saints* (1446) by the Venetian Antonio Vivarini in collaboration with Giovanni d'Allemagna, gold is used for the Madonna's halo and some of the brocade in the robes, but yellow pigments are used for the throne and paneled walls – so adroitly that the eye is almost fooled. Already the artist's skill is taking precedence over the value of the materials. The Magi are still awarded red-glazed gilt crowns in Vincenzo Foppa's *Adoration of the Kings* (c. 1510-1515), but the rest follows the Renaissance style. And Carlo Crivelli's *Annunciation, with St. Emidius* (1486) (Plate 21) presents us with immaculate, almost pedantic perspective and rich, varied use of color – yet the beam from heaven striking the brow of the Virgin is gold leaf. Here the nonnaturalistic character of the gilding serves to remind us that the heavenly ray is outside of nature. It is like a parting shot from the Middle Ages, before human experience displaced divine authority as the artist's guide and mentor.

As the materials lost their symbolic virtues, the painter's coloristic decisions became purely financial. The price lists of pharmacies – the main suppliers of artists' pigments in the early sixteenth century – give a good indication of why certain colours were preferred over others. In 1471 Neri di Bicci paid two and a half times as much per ounce for good azurite in Florence as for a good green (verde azuro, probably malachite), a good red lake, and a fine yellow lake (arzicha). Giallolino (here called giallo tedesco, probably lead-tin yellow) was one tenth the price of azurite, and white lead was a mere hundredth of the cost. Ultramarine, meanwhile, was ten times more expensive than azurite. So the price differential was vastly greater than what a painter would encounter today – no doubt with a proportionate influence on the choice of colors.

PHILIP BALL, *Bright Earth. Art and the Invention of Color*, The University of Chicago Press, 2001

17. Based on excerpt 1, Alberti:

- A) is convinced that colour has greater potential than gilding
- B) stigmatizes the use of metal as a display of conspicuous consumption
- C) is favourable to the use of gold only in certain light conditions and only to create certain effects
- D) exhorts the artisan to master the gold leaf technique
- E) believes gold is suited to enhance the three-dimensionality of represented objects

18. Based on *excerpt 1*, it is possible to say that:

- A) gilding became less popular and was increasingly used only for objects with symbolic value, for example in Carlo Crivelli's Annunciation.
- B) in the *Conversion of St. Hubertus*, the painter's timid interest in nature makes him decide not to represent the sky in a traditional manner
- C) Antonio Vivarini and Giovanni D'Alemagna did not use gold in the representation of the Virgin, except for her halo
- D) in Vincenzo Foppo's *Adoration of the Kings*, the gilding of the crowns is now considered a parting shot of the Renaissance
- E) gilding is replaced by pigments for purely economic reasons

19. Based on *excerpt 1*, it is possible to say that:

- A) as colours became less symbolic, painters' choices were influenced more by price
- B) the price of colours fluctuated enormously
- C) the price of colours varied enormously depending where they came from
- D) the difference in price between white lead and giallolino was 1 to 100
- E) the price of colours varied: the cheapest was white lead, the most expensive was giallolino

20. Based on *excerpt 1*, it is possible to say that:

- A) gilding limited the naturalistic trends that became popular during the Renaissance
- B) the use of gold leaf continued for a much longer period in northern Europe
- C) gold was finally replaced by "arzicha", the yellow pigment that was by far the cheapest
- D) from the Renaissance onwards gilding was reserved for the wealthiest clients
- E) metal was replaced by pigment by the end of the Middle Ages

General Culture Test

21. Which of these Life Senators was nominated by the President of the Republic Sergio Mattarella?

- A) Liliana Segre
- B) Carlo Rubbia
- C) Elena Cattaneo
- D) Mario Monti
- E) Renzo Piano

22. Which one of these film directors CANNOT be considered an exponent of neorealism?

- A) Franco Zeffirelli
- B) Roberto Rossellini
- C) Vittorio De Sica
- D) Pietro Germi
- E) Luchino Visconti

History Test

23. What happened on 27 January 1945?

- A) The Russians freed the Auschwitz prisoner of war camp
- B) The Allies entered Rome
- C) The Allies landed on the beaches in Salerno
- D) Bombs destroyed the city of Dresden
- E) The Red Cross denounced the genocide of the Jews



24. Which is the correct chronological order of the following individuals:

- A) Justinian, Charlemagne, Frederick Redbeard, Lorenzo the Magnificent, Charles V
- B) Charlemagne, Justinian, Charles V, Lorenzo the Magnificent, Frederick Redbeard
- C) Justinian, Charles V, Lorenzo the Magnificent, Frederick Redbeard, Charlemagne
- D) Charlemagne, Charles V, Justinian, Frederick Redbeard, Lorenzo the Magnificent
- E) Frederick Redbeard, Justinian, Charlemagne, Lorenzo the Magnificent, Charles V

25. Where did the Industrial Revolution start?

- A) England
- B) The Netherlands
- C) France
- D) The United States
- E) Russia

26. Which diplomat represented the Austrian Empire at the Congress of Vienna?

- A) Metternich
- B) Bismark
- C) Waldheim
- D) Radetzky
- E) Bullow

27. Who attended the Yalta Conference to shape a post-war peace?

- A) Stalin, Roosevelt, Churchill
- B) Stalin, Truman, Chamberlain
- C) Molotov, Roosevelt, Churchill
- D) Stalin, Truman, Chamberlain
- E) Stalin, Ribbentropp, Churchill

28. Which year is traditionally considered to mark the Fall of the Western Roman Empire?

- A) 476
- B) 313
- C) 800
- D) 625
- E) 576

29. In the Doryphoros, correspondence between the tense parts and the relaxed parts are based on a juxtaposed pattern called:

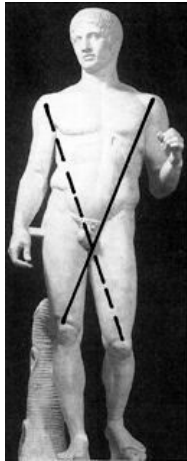

- A) Chiastic
- B) Counterpoint
- C) Antithesis
- D) Parellelism
- E) Golden Section

30. What is the name given to the slight curve of a column at approximately one third of its height?

- A) Entasis
- B) Echinus
- C) Fluting
- D) Abacus
- E) Tapering

31. What is the name of a ground plan with an elongated shaft and a shorter cross bar?

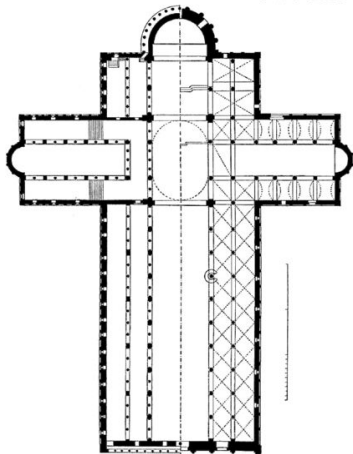

- A) Latin Cross
- B) Greek Cross
- C) Tau Cross or St. Antony's Cross
- D) St. Andrew's Cross
- E) Cross of Lorraine



32. The famous villa known as The Rotunda was designed by:

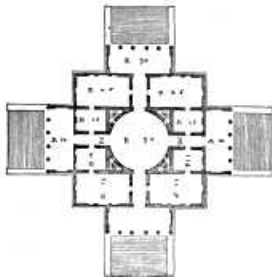
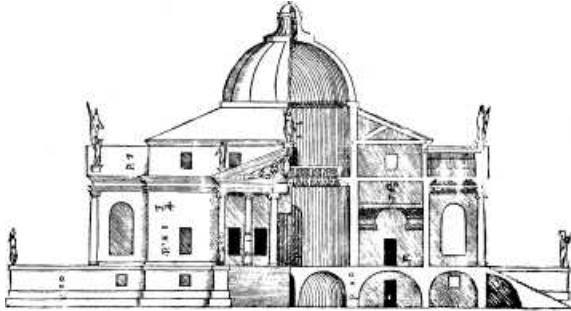

- A) Andrea Palladio
- B) Filippo Brunelleschi
- C) Leon Battista Alberti
- D) Donato Bramante
- E) Giuliano da Sangallo

33. When was Filippo Tommaso Marinetti's Manifesto of Futurism published in "Le Figaro"?

- A) 1909
- B) 1925
- C) 1930
- D) 1907
- E) 1913

34. The Tassel House designed by Victor Horta is an example of what style of architecture?



- A) Art Nouveau
- B) International Style
- C) Baroque
- D) Rococò
- E) Rationalism

35. Who is the painter of this work of art?

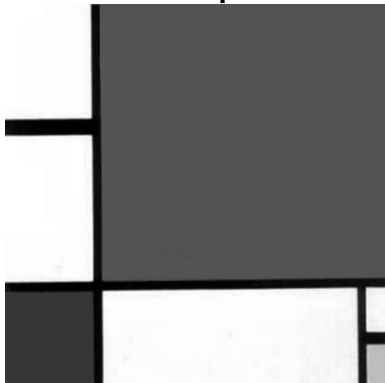

- A) Mondrian
- B) Braque
- C) Monet
- D) Modigliani
- E) Magritte

36. Who painted the fresco entitled "Allegory of Good and Bad Government" in the Palazzo Pubblico in Siena?

- A) Ambrogio Lorenzetti
- B) Simone Martini
- C) Duccio di Buoninsegna
- D) Giotto
- E) Cimabue



37. Who participated, together with Brunelleschi, in the competition for the panels to embellish the doors of the Baptistery in Florence?

- A) Lorenzo Ghiberti
- B) Domenico Ghirlandaio
- C) Leon Battista Alberti
- D) Giovanni Pisano
- E) Andrea del Verrocchio

38. Who designed the Guggenheim Museum in Bilbao?



- A) Frank O. Gehry
- B) Zaha Hadid
- C) Massimiliano Fuksas
- D) Renzo Piano
- E) Frank Lloyd Wright

Drawing and Representation Test

39. Match each Archimedean solid to its net image.

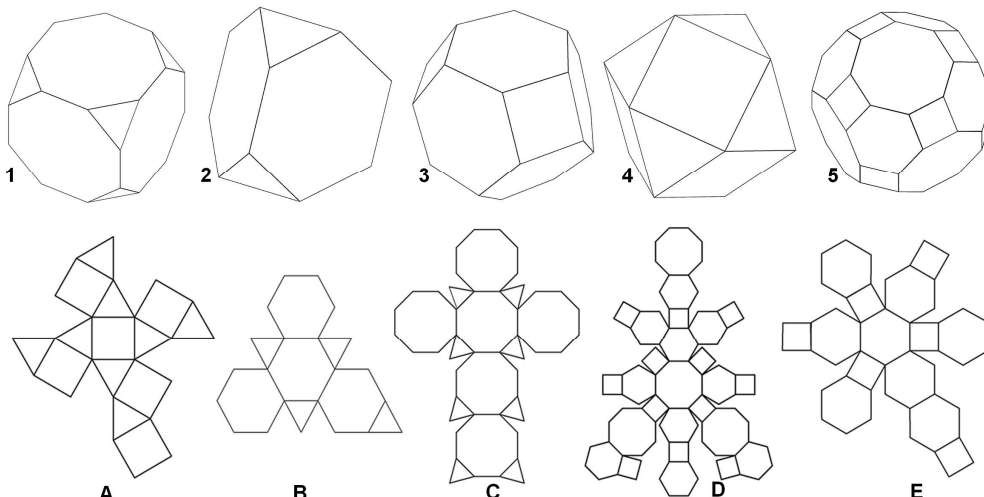

- A) 1C, 2B, 3E, 4A, 5D
- B) 1D, 2A, 3C, 4B, 5E
- C) 1B, 2C, 3E, 4A, 5D
- D) 1C, 2B, 3A, 4E, 5D
- E) 1D, 2A, 3E, 4B, 5C

40. The five important points in a triangle are:

- 1 – barycentre
- 2 – circumcentre
- 3 – incentre
- 4 – orthocentre
- 5 – the Fermat point

Match each one with the correct construction

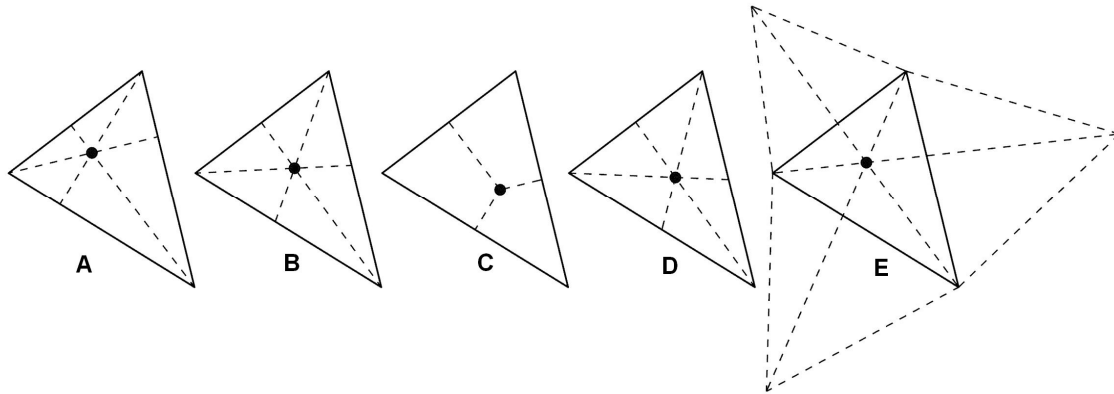

- A) 1D, 2C, 3B, 4A, 5E
- B) 1E, 2B, 3C, 4D, 5A
- C) 1D, 2C, 3A, 4B, 5E
- D) 1E, 2C, 3B, 4A, 5D
- E) 1D, 2C, 3B, 4E, 5A



41. Look at the plans and axonometric projections of these contemporary buildings and then identify the series that correctly matches the plans and their respective axonometric projections.

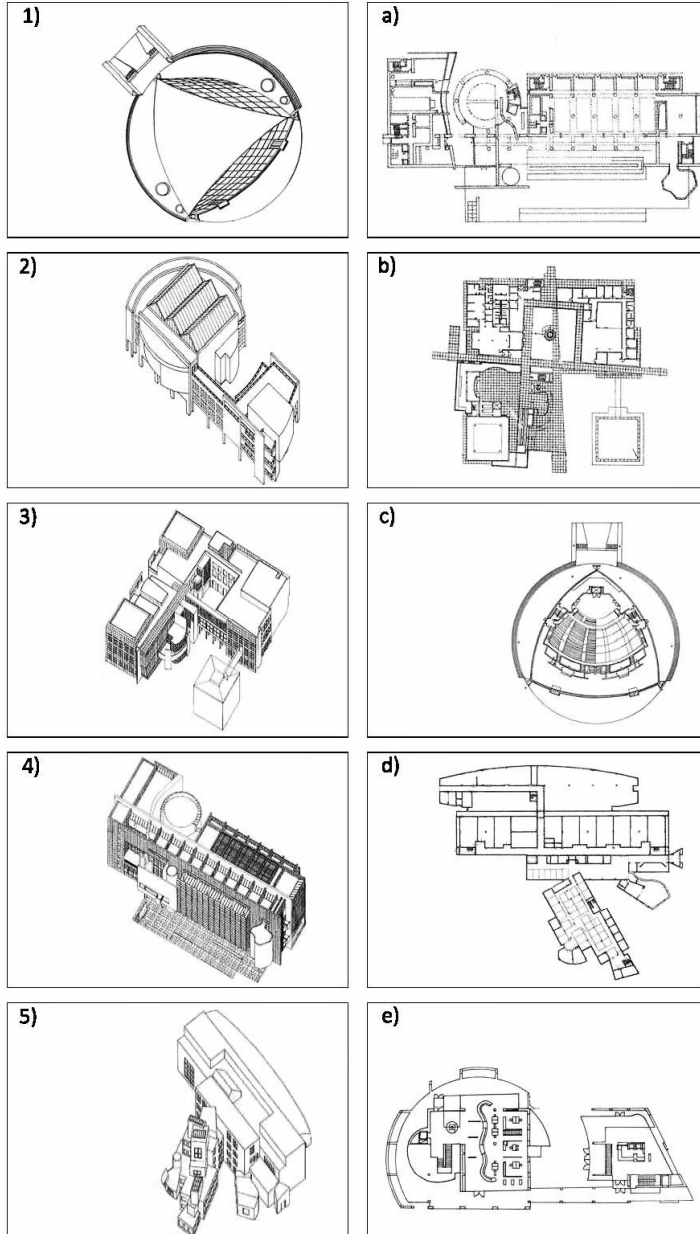

- A) 1c, 3b, 4a, 5d, 2e
- B) 1c, 5d, 3b, 2a, 4e
- C) 3b, 2e, 1c, 5a, 4d
- D) 1d, 2b, 5c, 4e, 3a
- E) 2e, 4a, 5d, 3c, 1b

42. Look at the axonometric drawing of the STELMAN CHAIR designed by G.T. Rietveld and then identify the corresponding, correct pair of orthogonal projections (front and side).

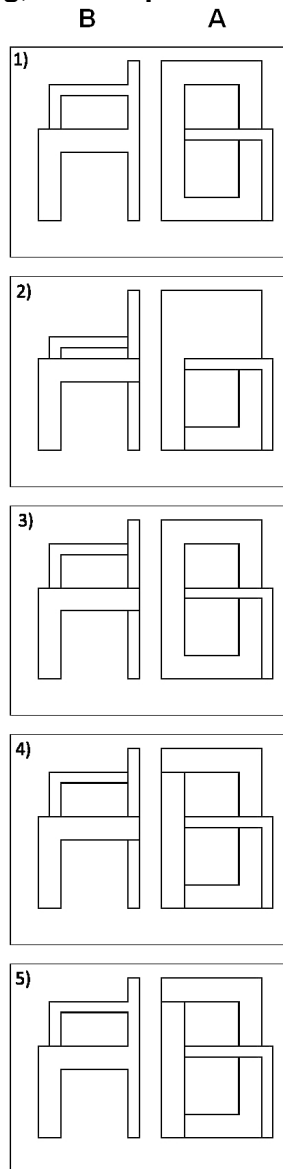
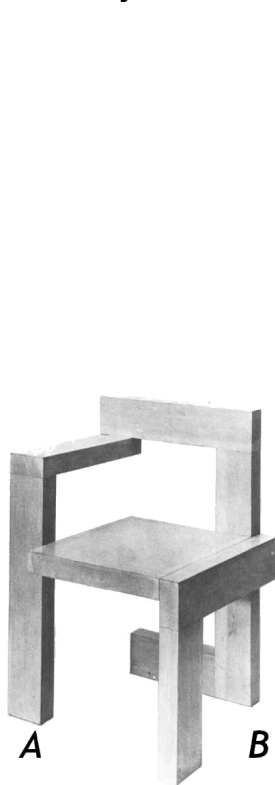

- A) 4
- B) 5
- C) 3
- D) 2
- E) 1



43. Look at the orthogonal projections of the architectural volume (plan and elevation) and then identify the axonometric projections corresponding to the orthogonal projections.

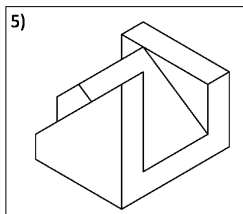
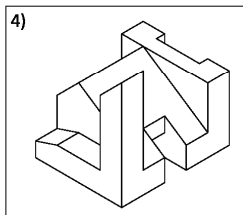
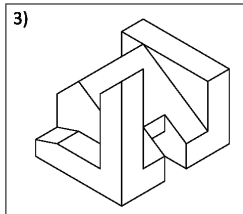
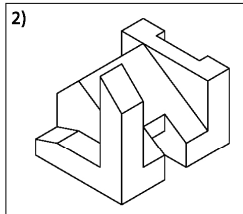
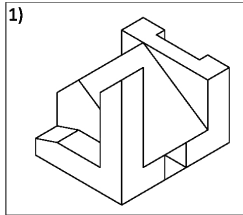
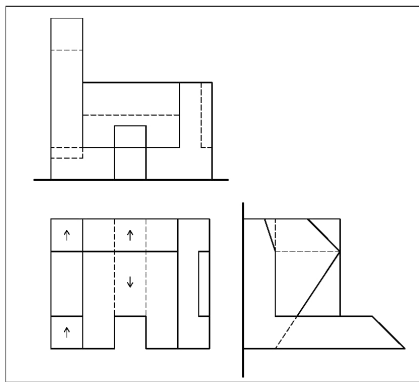

- A) 4
- B) 2
- C) 5
- D) 3
- E) 1

44. With reference to the plane sectioning the two solids (plan and elevation), identify the correct section.

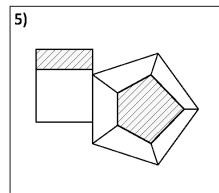
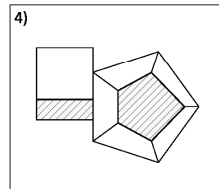
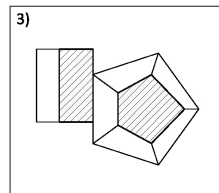
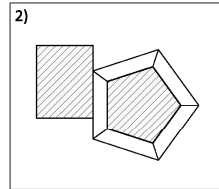
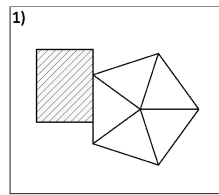
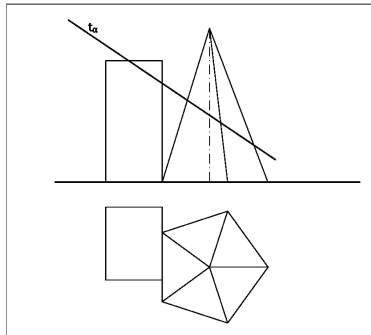

- A) 3
- B) 4
- C) 2
- D) 1
- E) 5



45. With reference to the plane sectioning the ensemble of the solids, identify the correct section.

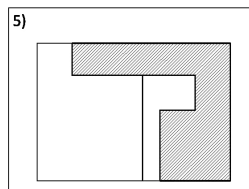
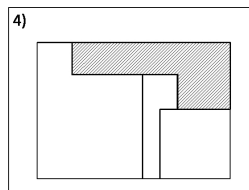
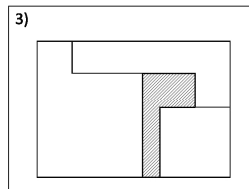
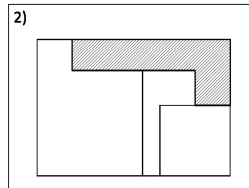
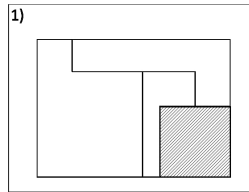
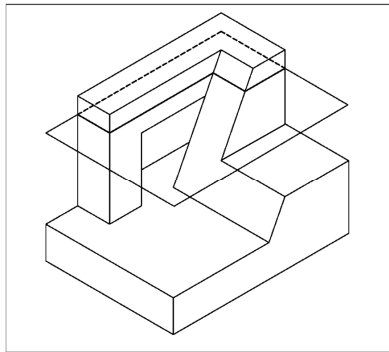

- A) 4
- B) 5
- C) 2
- D) 1
- E) 3

46. Match the plan to its corresponding frontal elevation.

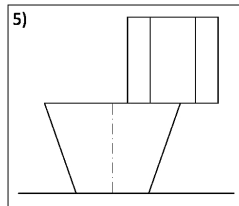
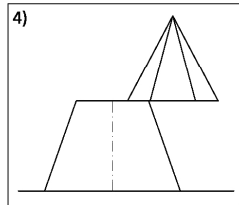
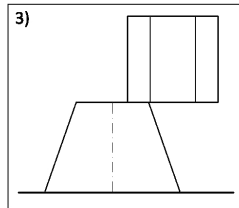
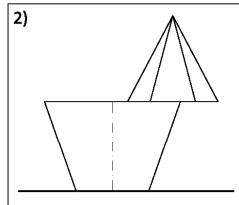
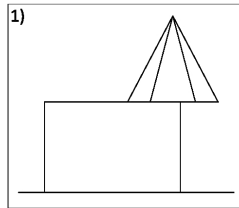
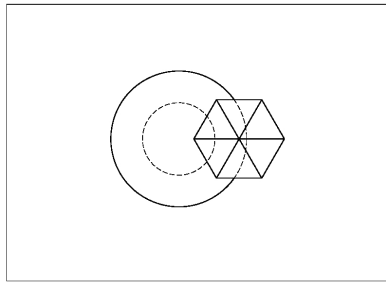

- A) 2
- B) 4
- C) 5
- D) 3
- E) 1



47. Match the axonometric projection of the volume with its corresponding plan.

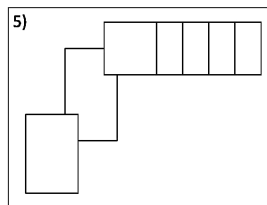
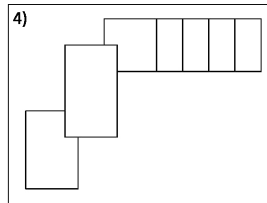
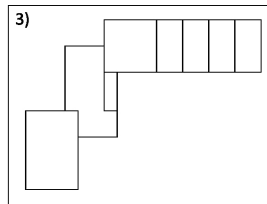
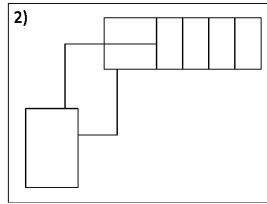
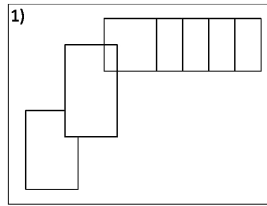
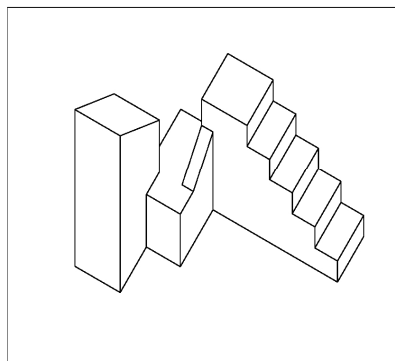

- A) 3
- B) 2
- C) 5
- D) 4
- E) 1

48. Look at the photographs of the buildings and their plans and then identify the series that correctly matches the plan and photograph of each building.

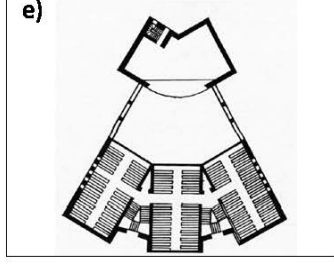
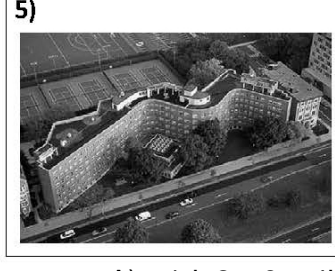
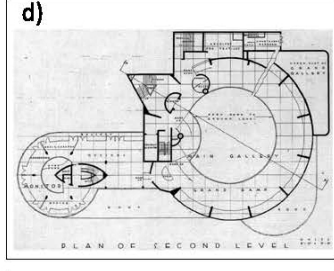
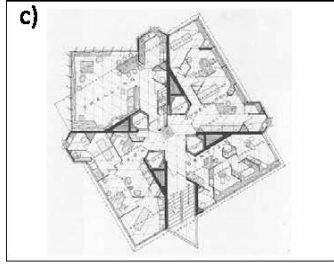
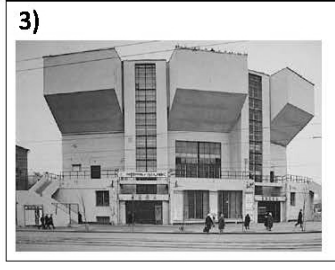
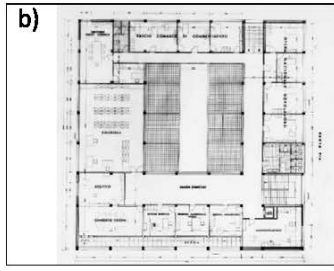
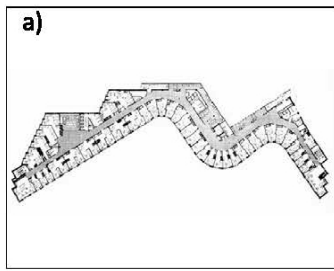

- A) 1d, 2c, 3e, 4b, 5a
- B) 4b, 3e, 5d, 1e, 2c
- C) 2c, 5a, 1d, 4e, 3b
- D) 5e, 1c, 2d, 3b, 4a
- E) 1d, 5a, 4c, 3e, 2b



Mathematics and Physics Test

49. The temperature in Kelvins of an ideal gas increases from 3K to 6K while its pressure remains constant. The volume of gas:
- A) doubles
 - B) quadruples
 - C) remains constant
 - D) is reduced by 50%
 - E) triples
50. Motorway guardrails are built of steel (linear expansion coefficient $\lambda = 1,7 \cdot 10^{-5} \text{ } ^\circ\text{C}^{-1}$). What would be the variation in length of a 250 m stretch measured in winter at $-5 \text{ } ^\circ\text{C}$ if it were measured in the summer at $35 \text{ } ^\circ\text{C}$?
- A) 17 cm
 - B) 1,7 cm
 - C) 1,7 m
 - D) 12,75 cm
 - E) 1,275 m
51. From a standstill an object moves with constant acceleration and covers 5 m in the first second. What distance does it travel in the next second?
- A) 15 m
 - B) 40 m
 - C) 10 m
 - D) 5 m
 - E) 30 m
52. Three small conducting spheres A, B and C have the same radius. Sphere A has a charge $2q$, sphere B has a charge q , while C is neutral. Sphere A is first placed in contact with B and then with C; after these two contacts what is the charge of A:
- A) $3q/4$
 - B) q
 - C) $5q/4$
 - D) $2q$
 - E) $3q$
53. A homogeneous lamina has the form of a triangle ABC rectangle in A with $\hat{C} = 30^\circ$. The lamina is attached to a vertical string passing through vertex A. What angle is formed by the string with side BA when the lamina is stable balanced position?
- A) 120°
 - B) 135°
 - C) 100°
 - D) 90°
 - E) 40°

54. The base of a triangle and its relative height measure respectively 25 cm and 12 cm. Given that the relative height of the other two sides are 15 cm and 20 cm, what is the measurement of the perimeter of the triangle?
- A) 60 cm
 B) 75 cm
 C) 72 cm
 D) 45 cm
 E) 100 cm
55. What is the solution of the inequality: $\sqrt{3-2x} < x$?
- A) $1 < x \leq \frac{3}{2}$
 B) $x < 1$
 C) $-3 < x \leq \frac{3}{2}$
 D) $-3 < x < 1$
 E) $x \leq \frac{3}{2}$
56. A box contains 4 red balls, 5 orange balls, 5 purple balls and 6 yellow balls. What is the probability that, pulling out two balls one after the other, and putting them back, only one purple ball will be pulled out?
- A) $\frac{3}{8}$
 B) $\frac{5}{16}$
 C) $\frac{16}{9}$
 D) $\frac{5}{8}$
 E) $\frac{3}{16}$
57. What is the value of the sum $\log 2 + \log \frac{3}{2} + \log \frac{4}{3} + \log \frac{5}{4}$?
- A) $\log 5$
 B) $\log 2$
 C) 0
 D) 1
 E) $\log \frac{14}{9}$
58. The measurements of the sides of a triangle ABC are 12 cm, 10 cm, and 3 cm. What kind of triangle is ABC?
- A) obtused-angled
 B) isosceles
 C) the data cannot represent the measurements of the sides of a triangle
 D) right-angled
 E) equilateral
59. What is the value of the area of the quadrilateral with the following points as vertices A(1,5) B(3,5) C(3,-3) D(-4,0)?
- A) 33
 B) 35
 C) 30
 D) 20
 E) 40



60. In the right-angled triangle ABC the sine of one of the acute angles is $\frac{8}{17}$, what is the value of the sine of the other acute angle?

- A) $\frac{15}{17}$
- B) $\frac{3}{5}$
- C) $\frac{15}{8}$
- D) $\frac{2}{5}$
- E) $\frac{8}{15}$

***** FINE DELLE DOMANDE *****

In tutti i quesiti proposti la soluzione è la risposta alla lettera A)